

Introducing ourselves



## Our company

Since 1991, Contibelt has been producing and developing CONVEBELT™ high quality conveyor- and process belts made of special solid steel and stainless steel materials. These form an integral part of a wide variety of industrial production processes. Today, we are a respected, worldwide company. From our headquarters in Austria, we supply our products and services to customers around the globe. In addition, Contibelt operates a service and maintenance network with local stations in a permanently increasing number of countries worldwide.

## Our structure

The Contibelt team consists of highly experienced specialists versed in using solid steel belts that are designed to meet customers' specific requirements for continuous systems. Our specialists are experts in designing and calculating steel belt conveyors, determining belt and system requirements, supervising the various manufacturing methods for belts and belt systems and finally providing after-sales service.

## Our business philosophy

We see our most important task in offering the best possible solution for our customers' specific problems, enabling them to manufacture their product with the greatest possible economy and technical perfection. Only satisfied customers guarantee a company's success, which is why we seek to supply you with the best product for your particular needs. And we provide quality: You will always receive the technologically most advanced final product from us.

## Our steel belt design

The design and quality of our products are chosen to conform to the customers' individual requirements with respect to strength, hardness, abrasion, corrosion resistance, thermal conductivity, thermal expansion and the like.

## Our innovations

Our focus on permanently taking further our production processes have made us become one of the most innovative steel belt suppliers on the market. Amongst other developments we have set a benchmark with our innovative attachment process for rubber v-ropes that allows a significantly more reliable attachment between steel belt and tracking ropes than conventional systems could.

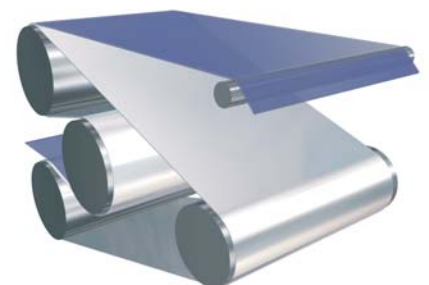
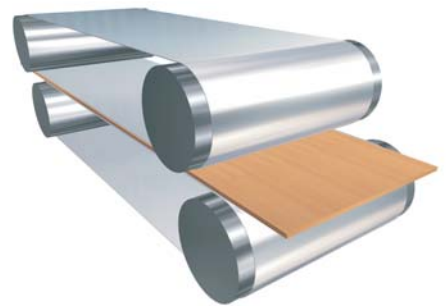
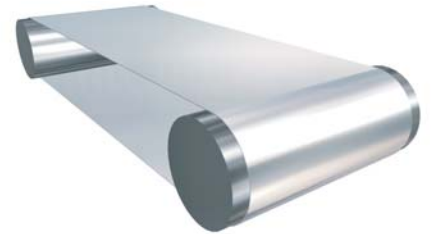

CONVEBELT - THE BELT FROM CONTIBELT

[www.contibelt.com](http://www.contibelt.com)

Contibelt Systems, Inc.

11565 Pearl Road, Suite 300  
Strongsville, OH 44136

e-mail: [band@contibelt.com](mailto:band@contibelt.com)

web: [www.contibelt.com](http://www.contibelt.com)

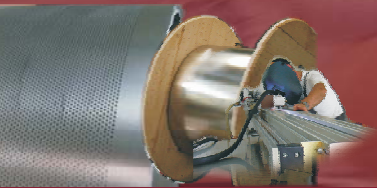

In this sector of industry, continuous conveyor belts are an integral part of production. Unlike conveyor belts used purely for transportation purposes, the surface and the material of belts used in the chemical industry have an important role to play. The conversion of individual products from a liquid into a solid state must be effected just as smoothly as the production of desired product surfaces. Stainless special steel belts with especially good welding properties are particularly well suited to such uses.

We recommend that you make no compromises on quality. A reliable belt should be used in the production of resins, waxes, paraffins, sulfur, phosphates, powder-coatings and the like - a belt from Contibelt, your belt designer.

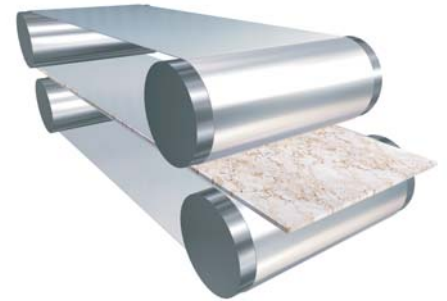

### Our delivery program:

Dimensions: width: 600 / 800 / 1000 / 1200 / 1500 / 1550 / 1570 (width in mm)  
24" / 32" / 40" / 48" / 59" / 61" (nominal width in inches)

thickness: 0.60 / 0.80 / 1.00 / 1.20 mm (thickness in mm)  
.024" / .032" / .040" / .048" (thickness in inches)  
(other dimensions available upon request)

Surface: mill finish according to ASTM standard 2B  
(other surface finishes available upon request)

Tolerances: width tolerance +/- 1 mm (+/- .040")  
thickness tolerance +/- 10 %

Belt materials: the appropriate steel belt material is depending on the customers' individual requirements and shall best be decided upon together with our experienced engineers who can choose from a wide variety of steel and stainless steel qualities which have been especially developed for steel belt applications. These materials include - among others - the following qualities:

CB 301 SGA	(cold rolled austenitic stainless steel)
CB 316 SGA	(austenitic stainless steel with improved corrosion resistance)
CB 31 SGM	(cold rolled martensitic stainless steel)
CB 630 SGM	(precipitation hardened, martensitic stainless steel)

Belt tracking: plain belt, without v-rope  
centered v-rope  
side v-rope(s)  
retaining rope(s)

Belt ends: prepared for field welding  
shop welded endless in our facilities

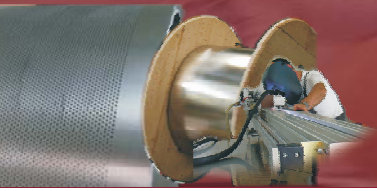

Contibelt belts are as endless as the number of their uses in the food industry. Here, the industry demands that the belts fulfill widely disparate requirements, depending on where they are utilized. Nevertheless, all these applications have one demand in common: the necessity of a hygienic stainless steel belt, which can easily be cleaned with hot water or steam.

The applications for our CONVEBELT™ steel belts range from meat processing plants to vegetable transportation and processing to freezing facilities, where operations are generally run on stainless steel belts. Furthermore, we offer special belts for baking processes, chocolate transport or other manufacturing processes.



### Our delivery program:

Dimensions: width: 600 / 800 / 1000 / 1200 / 1500 / 1550 / 1570 (width in mm)  
24" / 32" / 40" / 48" / 59" / 61" (nominal width in inches)

thickness: 0.60 / 0.80 / 1.00 / 1.20 mm (thickness in mm)  
.024" / .032" / .040" / .048" (thickness in inches)  
(other dimensions available upon request)

Surface: mill finish according to ASTM standard 2B  
(other surface finishes available upon request)

Tolerances: width tolerance +/- 1 mm (+/- .040")  
thickness tolerance +/- 10 %

Belt materials: the appropriate steel belt material is depending on the customers' individual requirements and shall best be decided upon together with our experienced engineers who can choose from a wide variety of steel and stainless steel qualities which have been especially developed for steel belt applications. These materials include - among others - the following qualities:

- CB 105 SGF (Cold rolled, hardened special steel with ferritic structure)
- CB 301 SGA (cold rolled austenitic stainless steel)
- CB 316 SGA (austenitic stainless steel with improved corrosion resistance)
- CB 31 SGM (cold rolled martensitic stainless steel)

Belt tracking: plain belt, without v-rope  
centered v-rope  
side v-rope(s)  
retaining rope(s)

Belt ends: prepared for field welding  
prepared for field riveting  
shop welded endless in our facilities



CONVEBELT - THE BELT FROM CONTIBELT

[www.contibelt.com](http://www.contibelt.com)

Contibelt Systems, Inc.

11565 Pearl Road, Suite 300  
Strongsville, OH 44136

e-mail: [band@contibelt.com](mailto:band@contibelt.com)

web: [www.contibelt.com](http://www.contibelt.com)



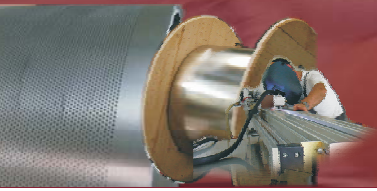

Steel belts play an essential role in modern, continuous production processes for wood based panels such as particleboards, OSB- and MDF boards, where they serve as heat and pressure transfer media at the same time. Presently, virtually every wood based panel is being produced with the help of highly resistant steel belts. As the steel belt surface has a direct influence on the final panel surface quality, this application imposes high demands on steel belts regarding thickness uniformity and surface finish. These requirements make our high tensile strength, PH-grade stainless steel belts a perfect choice. Depending on the individual requirements, they can be delivered either with a 2B mill finish or a ground surface finish.

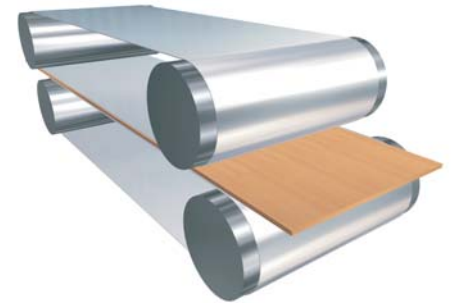

Our delivery program:

Dimensions: width: up to 1550 mm (61") (single width)
up to 2650 mm (104.3") (with one longitudinal weld)

thickness: 1.20 / 1.60 / 1.80 / 2.00 mm (thickness in mm)
.048" / .062" / .070" / .079" (thickness in inches)
(other dimensions available upon request)

Surface: mill finish according to ASTM standard 2B
ground on one or both sides

(the appropriate surface roughness should be chosen together with our experienced engineers)

Tolerances: width tolerance +/- 1 mm (+/- .040") (for single width belts)
thickness tolerance +/- 10 %

Belt materials: For this special, highly demanding application, we recommend using only high tensile strength, PH-grade stainless steels such as our quality CB 630 SGM, which was developed and optimized by our experienced technicians in cooperation with experts from recognized research institutes.

Belt ends: prepared for field welding
shop welded endless in our facilities



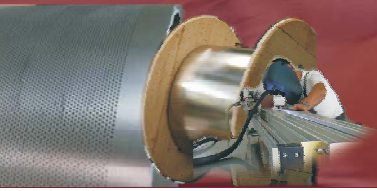

## CONVEROPE v-ropes



Solid steel belts can be tracked on a conveyor by several different methods. The belt can be delivered plain, which requires some external tracking method, or can be furnished with v-ropes attached to the bottom side which either ride in grooves or on the outside of the rotating drums or sheaves.

Contibelt has developed the unique CONVEROPE technology for attaching v-ropes to steel belts. This direct vulcanization method is using un-vulcanized rubber which is vulcanized directly on the steel belt. The v-rope material can be furnished with temperature resistance up to 135° C (275° F) and for special applications up to 180° C (356° F).

In contrast to our above described CONVEROPE direct vulcanization process, conventional v-rope attachment processes by hot-bonding, as used by most other steel belt producers, can only withstand comparably low temperatures of up to approx. 90° C (194° F).

Consequently, we are of the opinion that our v-rope is the best and most durable one available on the market.

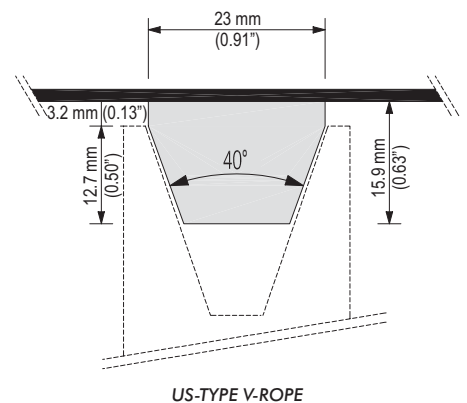
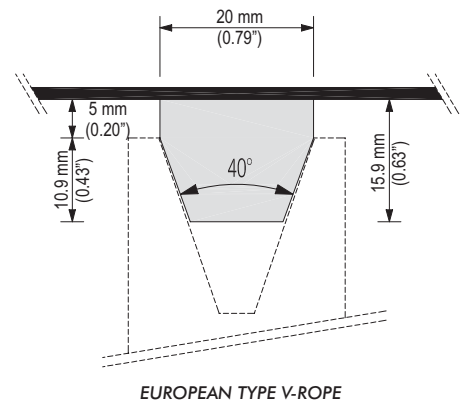
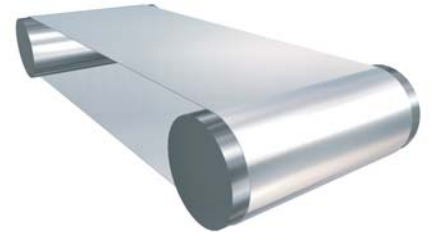

### Our delivery program:

**Dimensions:** Due to different regional standards, our v-ropes are available in different dimensions (see graphic)

**Qualities:** CONVEROPE<sup>CM</sup> Standard Nitrile:  
Contibelt's versatile standard v-rope is oil- and fat resistant and can withstand long term exposure to temperatures ranging from -40° C (-40° F) to 100° C (212° F).

CONVEROPE<sup>CM</sup> HTR (High Temperature Resistant):  
Special oil- and fat resistant v-rope with improved long term temperature resistance of up to 135° C (275° F).

CONVEROPE<sup>CM</sup> ULT (Ultra Low Temperature):  
Oil- and fat resistant v-rope which was especially developed for freezer applications with prevailing temperatures below - 40° C (- 40° F).

**Colors:** All our rubber qualities can be delivered either in black or gray colors.

CONVEBELT - THE BELT FROM CONTIBELT  
[www.contibelt.com](http://www.contibelt.com)

Contibelt Systems, Inc.

11565 Pearl Road, Suite 300  
Strongsville, OH 44136  
e-mail: [band@contibelt.com](mailto:band@contibelt.com)  
web: [www.contibelt.com](http://www.contibelt.com)

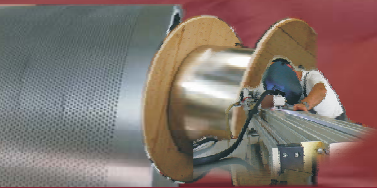

We at Contibelt are aware of the fact that after sales service is at least as important as producing and developing high quality stainless steel belts.

This is the reason why our technicians are permanently investigating new developments and processes to ensure the longest possible lifespan of our steel belts. And our success in the field of servicing and maintaining steel belts emphasizes the correctness of our service philosophy. Contibelt has, for instance, developed the revolutionary Converope Revultex process for repairing and re-attaching v-ropes on site, without the need to dismantle the machine or the steel belt.

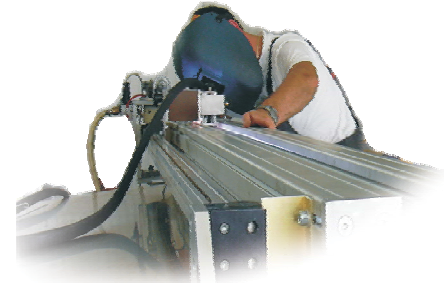

### Our service program:

**Welding:** Our experienced welding staff will assist you with any problem you might have with your solid steel belt, ranging from welding of small cracks to replacing entire parts of the belt.

**Contibelt REVULTEX:** Thanks to this revolutionary technology we are in the position of re-vulcanizing v-ropes, which have become loose during operations, onto the steel belt. In contrast to conventional repair methods of simply gluing a pre-vulcanized v-rope onto the belt, as still utilized by most other steel belt manufacturers, our Contibelt REVULTEX direct vulcanization technology ensures an attachment quality that is almost equal to the attachment quality of a new CONVEROPE v-rope, and, in our opinion, even more durable than a new v-rope attachment delivered by other steel belt manufacturers than Contibelt.

**Contibelt ANTIVEX:** By using our Contibelt ANTIVEX process, we can successfully reduce convex and concave deformations in your stainless steel belt as they might occur under certain circumstances during production processes. In case this process is applicable for your steel belt, it can help to considerably prolong its lifespan.

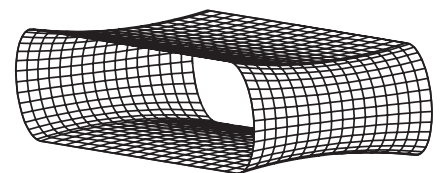
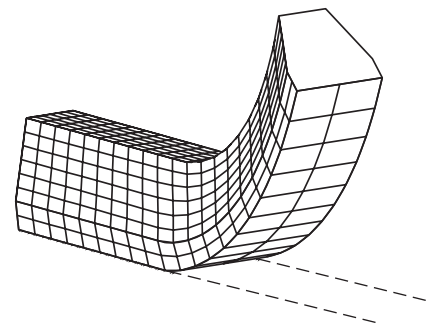

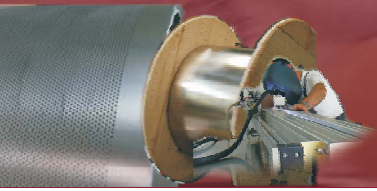

Contibelt offers its customers a wide range of steel belt materials in different dimensions and surface finishes for various applications. The following list will give an overview over the most common Contibelt steel belt materials and finishes. Nevertheless, as our specialists are permanently investigating new, optimized steel belt materials, the steel qualities for specific applications shall be discussed in detail - depending on individual requirements.

Contibelt was, for example, the first steel belt supplier to offer an easily weldable, microstructured special steel quality for chocolate transportation applications which helped eliminating the before prevailing, suboptimal riveted joints. This development considerably increased productivity while reducing maintenance costs in an entire industry.

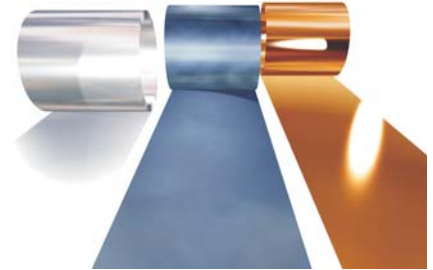

### Our delivery program (excerpt):

Steel qualities:	<b>CB 105 SGF</b>	Patented, cold rolled, microstructured special steel with ferritic structure. This steel quality is especially suitable for chocolate and cocoa mass transportation.
	<b>CB 301 SGA</b>	Cold rolled, stainless steel with an austenitic structure. In general, the material is in accordance with the ASTM - Standard AISI 301. Its high tensile strength characteristics, good corrosion resistance and good weldability make our CB 301 SGA a perfect choice for a wide variety of applications.
	<b>CB 316 SGA</b>	Cold rolled, stainless steel with an austenitic structure and increased corrosion resistance. In general, the material is in accordance with the ASTM - Standard AISI 316.
	<b>CB 31 SGM</b>	Cold rolled stainless steel with a martensitic structure. This steel quality with very good spring properties, high ductility, high tensile strength and very good weldability was especially designed for steel belt applications.
	<b>CB 630 SGM</b>	Cold rolled, precipitation-hardened stainless steel with martensitic structure, similar to AISI 630. This steel was especially designed for highly demanding steel belt applications and is characterized by high tensile and yield strength, high ductility, high fatigue strength, good corrosion resistance and good weldability.
Surfaces:	<b>mill finish</b>	mill finish according to ASTM standard 2B.
	<b>ground</b>	ground on one or both sides, available roughness: 2.5 µm (Rz) to 0.63 µm (Rz).
	<b>perforated</b>	a wide variety of perforations and special finishes is available upon request.